

## Thermal energy storage

Kemal Ermiş<sup>1</sup>, Fehim Findik<sup>2\*</sup>

<sup>1</sup>Mechanical Engineering Department, Sakarya Applied Sciences University, Esentepe Campus, Serdivan/Sakarya, Turkey

<sup>2</sup>Metallurgy and Materials Engineering Department, Sakarya Applied Sciences University, Esentepe Campus, Serdivan/Sakarya, Turkey

\*Corresponding author: [findik@subu.edu.tr](mailto:findik@subu.edu.tr)

© The Author

2020.

Published by

ARDA.

### Abstract

Thermal energy storage (TES) is an advanced energy technology that is attracting increasing interest for thermal applications such as space and water heating, cooling, and air conditioning. TES systems have enormous potential to facilitate more effective use of thermal equipment and large-scale energy substitutions that are economic. TES appears to be the most appropriate method for correcting the mismatch that sometimes occurs between the supply and demand of energy. It is therefore a very attractive technology for meeting society's needs and desires for more efficient and environmentally benign energy use. In this study, thermal energy storage systems, energy storage and methods, hydrogen for energy storage and technologies are reviewed.

*Keywords:* Energy storage & systems; Thermal energy; Hydrogen & production; Environment & problems; Energy savings; Applications & performance

### 1. Introduction

Energy is required for several reasons; the most basic and obvious is to prepare food and provide heat to make life comfortable or at least bearable. Later, a wide range of technological uses of energy emerged and developed, so the availability of energy became a central issue in society [1]. The easiest way to obtain useful energy is simply to find it as wood or hydrocarbon fossil fuel in nature. However, it is advantageous to convert what is available in nature into more useful forms. The processing and conversion of raw materials, especially petrochemicals, has become a huge industry [1].

Thermal energy storage (TES) is one of the key technologies for energy saving and therefore has great practical significance. One of its main advantages is that it is best suited for heating and cooling thermal applications. TES is perhaps as old as civilization itself. Since the recorded time, people collected ice and kept it for later use. Large TES systems have been used for many applications in the recent past, from solar hot water tanks to building air conditioning systems. TES technology has recently been developed to a point that can have a significant impact on modern technology [2].

In general, a series of coordinated actions must be taken in various sectors of the energy system to realize the maximum potential benefits of thermal storage. TES seems to be an important solution to correct the mismatch between energy supply and demand. TES can contribute significantly to meeting the needs of the society for more efficient, environmentally safe energy use. TES is an essential component of many successful thermal systems, and a good TES should allow for the smallest amount of thermal losses leading to energy savings while allowing the highest reasonable extraction efficiency of stored thermal energy [2].

There are mainly two types of TES systems, namely logical (eg water and rock) and latent (eg water / ice and salt hydrates). There is a wide variety of options for each storage medium, depending on the temperature range

and application. TES drew great attention with latent heat. Perhaps the clearest example of hidden TES is water turning into ice. Cooling systems with ice storage have a significant size advantage over equivalent capacity chilled water units, since large amounts of energy can be stored as latent heat. TES usually deals with the storage of energy by cooling, heating, melting, solidifying or evaporating a substance, and when the process is reversed, the energy becomes usable as heat. The choice of a TES mainly depends on the required storage time, ie daily or seasonal, economic viability, working conditions, etc. In practice, many research and development activities related to energy have led to energy savings by focusing on efficient energy use and energy savings. In this context, TES seems to be an attractive thermal application. In addition, exergy analysis is an important tool for analyzing TES performance [2].

## **2. Energy storage systems**

### **2.1 Introduction**

Energy storage (ES) has recently been developed to a point where it can have a significant impact on modern technology. In particular, ES is critical to the success of any intermittent energy source in meeting demand. For example, the need for storage for solar applications is particularly severe when solar energy is minimal at winter [2]. ES systems can contribute significantly to meeting the needs of society more efficiently and environmentally. It uses good energy in building heating and cooling, aviation power and utility applications. The use of ES systems often provides significant benefits such as:

- reduced energy costs;
- reduced energy consumption;
- improved indoor air quality;
- increased working flexibility; and
- reduced start-up and maintenance costs [2].

In addition, Dincer [3] highlights some other advantages of ES:

Reduced equipment size;

- more efficient and effective use of the equipment;
- preservation of fossil fuels (by facilitating more efficient energy use and / or fuel replacement); and
- reduced pollutant emissions (eg CO<sub>2</sub> and chlorofluorocarbons (CFCs)).

ES systems have enormous potential to increase the effectiveness of the use of energy conversion equipment and facilitate large-scale fuel substitutes in the world economy. ES is complex and cannot be properly evaluated without detailed knowledge of energy sources and end-use issues. Generally, in order to realize the maximum potential benefits of ES, a series of coordinated actions are needed in various sectors of the energy system. ES performance criteria can help determine whether forward-looking advanced systems have performance features that make them useful and attractive, and therefore it is worth following in advanced development and demonstration stages. However, the values of potential ES systems need to be measured in terms of the conditions expected after completion of research and development. Care should be taken not to apply a very narrow set of estimates to these conditions. In addition, care must be taken to evaluate certain storage system concepts in terms of terms that describe their full potential effects. The versatility of some ES technologies in a number of application areas should be considered in these evaluations [2].

### **2.2 Energy demand**

Energy demand in the commercial, industrial, public, residential and utilities sectors varies by day, week, and season. Ideally, these demands are matched with various energy conversion systems that operate synergistically. Providing peak hours is the most difficult and expensive. Peak electricity demands are usually met by conventional gas turbines or diesel generators that are expensive and relatively little dependent on oil or gas. ES provides an alternative method to meet the highest energy demands. Similarly, ES systems can improve the

operation of cogeneration, solar, wind and river water hydroelectric facilities. Some details about these ES applications are as follows [2]:

- **Benefit.** Relatively inexpensive basic charge electricity can be used to charge ES systems in the evening or intense weekly or seasonal periods. Electricity is then used in peak periods, which reduces trust in conventional gas and oil peak generators.
  - **Industry.** High temperature waste heat from various industrial processes can be stored for use in preheating and other heating processes.
  - **Cogeneration.** A close match of heat and electricity with a cogeneration system rarely meets the demand, so excess electricity or heat can be stored for subsequent use.
  - **Wind and river current hydro.** Probably, these systems can operate at any time of the day, charge an electrical storage system at low demand times and then use this electricity for peak purposes. ES increases the capacity factor of these devices and generally increases their economic value.
  - **Solar energy systems.** By storing excess solar energy received on sunny days for use on cloudy days or at night, ES systems can increase the capacity factor of solar energy systems.

### 2.3 Energy storage

Mechanical and hydraulic ES systems usually store electricity by converting electricity into compression, height, or rotational energy. The pumped storage space has been proven, but is very limited in terms of field issues and applicability. Compressed air ES has been successfully tested in Europe, but there are limited applications in the United States. This concept can be applied on a large scale using depleted natural gas fields for the storage reservoir. Alternatively, it can be stored chemically as hydrogen in energy-depleted gas fields. Rotational energy can be stored in flywheels, but it seems that advanced designs with high tensile materials are needed to reduce the price and volume of storage. A significant energy penalty of up to 50% usually occurs in a full storage cycle by mechanical and hydraulic systems due to inefficiencies.

Reversible chemical reactions can also be used to store energy. There is an increasing interest in the storage of low temperature heat in chemical form, but practical systems have not yet emerged. Another idea in the same category is to store hydrogen in metal hydrides (eg lanthanum). Tests for this idea continue.

Electrochemical ES systems have better return efficiency, but their prices are very high. Intensive research is now geared towards the development of batteries, reducing weight / storage capacity ratios as required in many vehicle applications. As the successor of the lead-acid battery, sodium-sulfur and lithium-sulfur alternatives are tested, among others. A different type of electrochemical system is a redox flow cell, because charge and discharge are achieved through reduction and oxidation reactions occurring in liquids stored in two separate tanks. To make the leading candidate (iron redox system) competitive with today's batteries, its price must be at least halved.

Thermal energy storage (TES) systems are diverse and include designed containers, underground aquifers and soils and lakes, bricks and ingots. Some systems using bricks operate in Europe. In these systems, energy is stored as sensitive heat. Alternatively, thermal energy can be stored at latent melting heat in materials such as salts or paraffin. Hidden warehouses can reduce the volume of the storage device by up to 100 times, but after several decades of research, most of its practical problems are still unresolved. Finally, electrical energy can be stored in superconducting magnetic systems, although these systems are costly [2].

### 2.4 Energy storage methods

Storage is very important for many energy technologies. Considering the storage of fuels as the storage of the energy placed in it, oil is an excellent example. It is necessary for the reliable, economical usability of large amounts of oil, gasoline, fuel oil and petrochemicals stored worldwide.

Electric vehicles store energy using a scheme called pumped storage. Electricity produced by thermal power plants employs large electric motors to pump water uphill to high reservoirs during periods of low electricity

demand. In peak demand periods, water is allowed to flow back downhill to restore energy through hydroelectric generation. In addition, electricity can be stored in batteries. However, today's conventional car battery is used to start the internal combustion engine, not to use motion, to use an important and common example. However, progress has been made in automotive batteries to store the energy of vehicles. ES includes heat storage. Thermodynamically, such tanks retain the transferred heat before being brought to useful purposes. A traditional example is the storage of hot water in residences and industry. This type of heat storage facilitates hot water or steam distribution, but is often ignored for more than a day.

Advanced new storage devices are often an integral part of other new technologies, and these can sometimes be made more practical with innovations in storage. Developments in storage area benefit especially wind and solar energy technologies. In addition, new storage technologies can facilitate the development of electrically powered cars.

A wide variety of ES techniques are being developed. We will discuss them by category, group the techniques that store energy in the following ways: mechanical, thermal, chemical, biological and magnetic, as shown in Figure 1. Of course, ES devices can be classified and categorized in other ways. Here, each category takes into account the storage of an energy form. Below, several possible storage options are briefly examined [4].

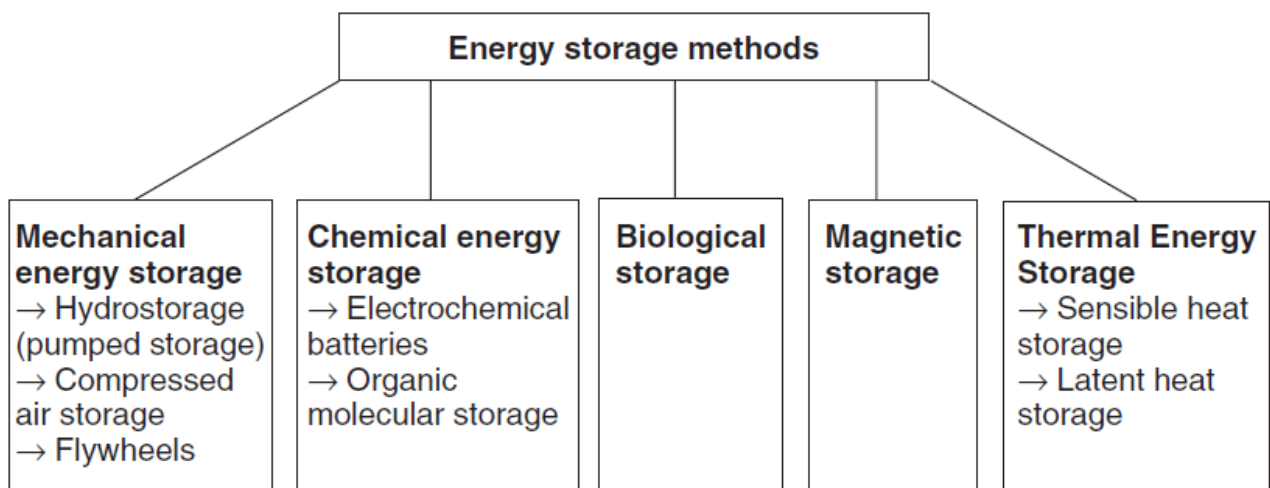

Figure 1. A classification of energy storage methods [4]

## 2.5 Hydrogen for energy storage

Energy can be stored in its chemical form as hydrogen. The potential versatility of this low-density gas for storing and transmitting energy has made it a comprehensive research topic over the past few decades and has increasingly moved to energy news. The variety of end uses for which hydrogen is well adapted includes being a chemical product, as well as fueling and powering transport vehicles for generating electricity and / or heat in fuel cells or combustion engines [2].

### 2.5.1 Storage characteristics of hydrogen

Hydrogen is not a source of energy. It is not present in its remarkably pure form on the planet. Instead, hydrogen is useful today as an intermediate form of energy (a "energy carrier") as well as using electrical energy. Hydrogen has many advantages over electricity and is therefore generally considered a complementary form of intermediate energy. In particular, hydrogen can be stored more easily and cheaper than electricity, and can provide a wide variety of end-use forms (including electricity). Hydrogen is less advantageous than electricity in terms of production costs [2].

Hydrogen has its advantages and disadvantages as a tool for storing energy. The energy density is high by mass (116,300 kJ / kg) compared to 46,520 kJ / kg for jet aviation fuel and liquid methane, for example. However,

hydrogen has a very low volumetric energy density and therefore usually requires a large storage volume. For example, the volumetric energy density of liquid hydrogen is only  $20.9 \times 106 \text{ kJ} / \text{m}^3$  compared to  $34.84 \times 106 \text{ kJ} / \text{m}^3$  for gasoline.

### **2.5.2 Hydrogen storage technologies**

Storing hydrogen is more difficult than most conventional chemical fuels. For example, while gasoline can be stored in a relatively inexpensive tank, hydrogen requires either an expensive high-pressure tank where steel is 100 times heavier than stored hydrogen, or a cooled, vacuum-insulated dewar system that is both expensive and energy-consuming. An alternative hydrogen storage system absorbs hydrogen from metallic powders to form hydrogen metallic compounds (metal hydrides). These can be separated by applying heat by applying hydrogen [2].

An additional favorable feature of metal hydrides is that they release the hydrogen steadily at approximately constant pressure. In a given volume, metal hydrides can hold some hydrogen as it can be stored as a liquid. However, metal hydrides are dense, so most of the weight in a storage system is due to metal, not hydrogen. A good candidate for metal hydride storage is iron-titanium.

### **2.5.3 Hydrogen production**

The most commercially available hydrogen is currently produced from hydrocarbons, such as methane or other gases, and oil or similar petroleum products. The raw material that most hydrogen will be produced in the future is the abundant water. By applying the required amount and energy form, water can be separated into hydrogen and oxygen. A significant amount of hydrogen is already produced by the electrolysis of water. Water electrolysis is a relatively simple process in which positive and negative electrodes are immersed in water and a voltage is applied. Gas bubbles appear - hydrogen on the negative electrode and oxygen on the positive electrode. Gases are prevented from spreading to the other electrode by diaphragms that allow electric current to pass, but do not allow gas. In a perfectly efficient electrolytic cell, 94 kWh of energy is needed to produce 28.3m<sup>3</sup> of hydrogen (at atmospheric pressure). Only 79 kWh of that energy has to be electrical; the other 15 kWh of energy can be heat. This latter requirement can be exploited by power engineers, as a large electric power plant can provide an electrolysis plant with both electrical and thermal energy, the latter being otherwise unused. At present, most electrolysis cells operate at energy efficiencies of about 60–75%, although it is noted that they use a high-quality form of energy (electricity) to make a slightly lower quality form (chemical energy as hydrogen). The prospects for large-scale electrolysis as a future process are not great. A process that generates inexpensive electricity will likely make electrolytic production of hydrogen more commercially attractive [2].

## **2.6 Comparison of ES technologies**

In the past, many attempts have been made to compare ES technologies by factors such as efficiency, cost, application and many other technical features. In addition to the main ES technologies discussed in this section, others are not mentioned for various reasons. Uncertainties regarding many ES technologies are evident in the tables on current capabilities and future expectations and expectations.

## **3. Thermal energy storage (TES) methods**

### **3.1 Introduction**

Energy demands in the commercial, industrial and public service sectors vary on a daily, weekly and seasonal basis. These demands can be matched with synergistically operating thermal energy storage (TES) systems. The use of TES has recently attracted a lot of attention for thermal applications such as space and water heating, cooling, air conditioning etc. As industrial countries become extremely electric, various TES techniques have been developed over the past four or five years. Such TES systems have enormous potential to make the use of

thermal energy equipment more effective and to facilitate economically large-scale energy substitutions. In general, a series of coordinated actions are required in various sectors of the energy system to fully realize the potential benefits of thermal storage.

TES deals with the storage of energy by cooling, heating, melting, solidifying or evaporating a material; thermal energy becomes available when the process is reversed.

Storage by causing a material to rise or fall in temperature is called logical heat storage; its effectiveness depends on the specific temperature of the storage material and its density if volume is important. Storage with phase change (transition from solid to liquid or liquid to vapor without temperature change) is a TES mode known as latent heat storage. Sensitive storage systems generally use rocks, soil or water as storage media and the thermal energy storage medium is stored by increasing the temperature. Hidden heat storage systems store energy in phase change materials (PCMs); The thermal energy stored when the material phase changes, usually from solid to liquid. The specific heat of solidification / fusion or evaporation and the temperature at which phase change occurs are important for design. Both sensitive and hidden TES can occur in the same storage material. In this section, TES is thought to involve the storage of heat by reversible scission or by reshaping chemical bonds.

TES technology has been used in a variety of shapes and applications. Some of the more common applications include the use of sensitive TES (oils, melted salts) or latent TES (ice, phase change material) for cooling and / or space heating and cooling needs. TES related research activities continue in various national laboratories, universities and research centers and industrial facilities around the world [2].

### 3.2 Thermal energy

Thermal energy amounts differ in temperature. As the temperature of a substance increases, its energy content also increases. The energy required to heat the volume of a substance from T1 to T2 is given by E.

$$E = mC (T2 - T1) = \rho VC (T2 - T1)$$

where C is the specific heat of the substance. A certain amount of energy can heat the same weight or volume of other substances and raise the temperature to a higher or lower value than T2. The C value can range from approximately 1 kcal / kg suC for water to 0.0001 kcal / kg °C for some materials at very low temperatures. The energy absorbed by a material as its temperature is lowered or its temperature increases by a material is called sensible heat.

Latent heat is associated with a material's state change or phase change. For example, energy is needed to turn ice into water, turn water into steam and melt paraffin wax. The energy required to cause these changes is called fusion heat at the melting point and evaporation heat at the boiling point. To illustrate, let's consider the water and suppose we want to boil 1 kg of ice into liquid and boil it until it evaporates. In this case, 80 kcal is required to dissolve ice at 0 ° C to water at 0 ° C; then about 100 kcal is required to raise the temperature of the water to 100 ° C; Finally, 540 kcal with a total energy requirement of 720 kcal is required to boil the water. The sensible heat varies from one material to another for a given temperature change. Latent heat varies significantly between different substances for a particular type of phase change.

It is relatively easy to determine the value of sensible heat for solids and liquids, but the situation is more complex for gases. If a restricted gas is heated in a certain volume, both temperature and pressure will increase. In this case, the specific heat observed is called the specific heat at a constant volume, Cv. Instead, the volume is allowed to change and if the pressure is fixed, the specific heat at constant pressure, Cp, is obtained. The Cp / Cv ratio and the fraction of heat generated during compression can be recorded, which significantly affects the storage efficiency [2].

### 3.3 Thermal energy storage

TES, which is an advanced energy technology, has attracted increased interest in thermal applications such as space heating, hot water, cooling and air conditioning. TES systems have the potential to increase the effective use of thermal energy equipment and to facilitate large-scale fuel migration. Most importantly, TES is useful for addressing the mismatch between energy supply and demand.

There are basically two types of TES systems, which are logical (eg water and rock) and latent (eg water / ice and salt hydrates). The choice of a TES system mainly depends on the required storage time, eg daily or seasonal, economic viability, working conditions, etc. Many energy research and development activities have focused on efficient energy use and energy conservation, and TES seems to be one of the more attractive thermal technologies developed.

TES is basically a temporary retention of energy for later use. The temperature at which the energy is kept partly determines the potential application. Examples of TES systems are storing solar energy for night and weekend use, summer heat for winter space heating and ice in winter for space cooling in summer. In addition, electrically generated heat or cold during off-peak hours can be used during subsequent peak demand hours. Unlike solar energy, fossil, nuclear and some other fuels, it is not always available. Even cooling loads, which coincide with the maximum solar radiation levels but are delayed in a certain time period, are often found after sunset. TES can provide an important mechanism to balance this mismatch between energy availability and demand times. Increasing social energy demands, fossil fuel shortages and concerns about environmental impact accelerate the development of renewable energy sources such as solar, biomass and wind energies. Because they are intermittent, the effective use of these and other energy sources depends in part on the availability of efficient and effective energy storage systems.

TES involves heating (or cooling) or melting or evaporating (or solidifying or liquefying) a material, or storing energy by thermochemical reactions. When the process is reversed, energy is recovered as heat or cold. Storage causing temperature rise is known as sensitive TES, and it is known as causing a phase change as latent TES. Thermochemical thermal storage, in which a reversible chemical reaction absorbs energy. TES has a wide range of applications, mostly related to heating and cooling. TES provides a connection and buffer between a heat source and a heat user. A common example of TES is the solar hot water storage system. The energy source is solar radiation and the heat user is the person who requests hot water. In this case, storage is necessary because the energy supply rate is small compared to instant demand and solar radiation is not always available when hot water is demanded.

As an example of cost savings and increased efficiency that can be achieved with the use of TES, consider the following situation. In some climates, it is necessary to provide heating in winter and cooling in summer. Typically, these services are provided using energy to operate the heaters and the air conditioner. With TES, it is possible to store heat in the warm summer months for use in the winter, while cold ambient temperatures in the winter can charge a cool store and then provide cooling in the summer. This is an example of seasonal storage that can be used to help meet energy needs caused by seasonal temperature fluctuations. Obviously, such a scheme requires a large amount of storage capacity due to large storage times. The same principle can be applied on a smaller scale to correct daily temperature changes. For example, solar energy can be used to heat tiles on a floor throughout the day. At night, as the ambient temperature drops, the tiles release their stored heat to slow down the temperature drop in the room.

Another example of TES application is the use of thermal storage to take advantage of off-peak electricity tariffs. Chiller units can be operated at night when the cost of electricity is relatively low. These units are then used to cool a thermal tank that provides cooling for air conditioning throughout the day. Not only can electricity costs be reduced, but because of lower nighttime ambient temperatures, the efficiency of the chiller improves and the highest electricity demand for electricity supply services is reduced [13].

### 3.4 TES methods

TES can assist in the efficient use and maintenance of thermal energy when there is a mismatch between energy production and use. Various subgroups of TES processes have been researched and developed for building heating and cooling, industrial applications, grid and space power systems. Storage time is an important factor. Daily storage systems have certain advantages: capital investment and energy losses are generally low and units are smaller and can be easily produced off-site. The daily storage size for each application is not as critical as the larger annual storage space. However, annual storage can only become economical in multi-dwelling or industrial park designs and often requires expensive energy distribution systems and new institutional arrangements for ownership and financing. In Solar TES applications, the optimum energy storage time is usually the time that delivers the final energy delivered at minimum cost when integrated into the collector field and backed up to a final application.

Some of the media available for sensible and the latent TESs are classified in Table 1.

Table 1. Available media for sensible and latent TES systems [13]

Enrollment in local colleges, 2005

<b>Sensible short term</b>	<b>Long term (annual)</b>	<b>Latent Short term</b>
Rock beds	Rock beds	Inorganic materials
Earth beds	Earth beds	Organic materials
Water tanks	Large water tanks	Fatty acids
-	Aquifers	Aromatics
-	Solar ponds	-

## 4. Environmental impact

### 4.1 Introduction

Energy supply and use relates not only to problems such as global warming, but also to environmental concerns such as air pollution, depletion of the ozone layer, forest destruction and emissions of radioactive materials. While maintaining a healthy and clean environment, if human society is to develop in the future, these and other environmental issues should be considered. Much evidence suggests that if people and communities continue to disrupt the environment, the future will be negatively affected.

There is a close link between energy, environment and sustainable development. A society seeking sustainable development should ideally use only energy sources that do not cause environmental impact (eg environmentally friendly or only harmless emissions). However, it is logical to suggest that some (but not all) concerns about environmental emissions and the limitations imposed on their sustainable development can be overcome with increased energy efficiency, since all energy sources have some environmental impact. There is a strong correlation between energy efficiency and environmental impact, as less resource use and pollution are normally associated with higher efficiency processes for the same services or products.

Thermal energy storage (TES) systems can contribute significantly to meeting the needs and demands of the society for more efficient, environmentally friendly energy use in applications such as building heating and cooling and electrical energy production and distribution. The use of TES systems generally provides significant benefits such as: [5, 6]:



- reduced energy costs;
- reduced energy consumption;
- improved indoor air quality;
- increased flexibility of operation;
- decreased initial and maintenance costs;
- reduced equipment size;
- more efficient and effective utilization of equipment;
- conservation of fossil fuels (by facilitating more efficient energy use); and
- reduced pollutant emissions (e.g., CO<sub>2</sub>).

## 4.2 Energy and the environment

Finding solutions to the environmental problems we face today requires long-term planning and actions, especially if we are going to approach sustainable development. In this context, it is seen that renewable energy sources represent one of the most advantageous solutions. Therefore, there is a strong link between renewable energy and sustainable development.

Energy is the technology currency that can be converted in many ways. Without energy sources, our societies cannot function and disintegrate. The impact of only a 24-hour outage in electricity supply to a city indicates how fully we depend on this particularly useful form of energy. Computers and elevators stop working, hospitals fall to the level of basic care and maintenance, and the lights go out.

The average annual growth rate in the world population is about 2%, and many countries exceed this level. As the population grows, the need for more and more energy sources increases. Developed lifestyles and energy demand often go up together. Currently, there is a huge disparity between the country's population and its wealth and energy use. The rich industrialized economies of the world, which includes 25% of the world's population, consume about 75% of the world's energy supply [7].

The world population is expected to double in the middle of the 21st century, and economic development will almost certainly continue to grow. Global demand for energy services is expected to increase in order of magnitude by 2050, while primary energy demands are expected to increase 1.5-3 times. Concurrently, concerns about energy related environmental issues such as acid deposition, stratospheric ozone depletion and global climate change will increase [8]. In recent years, more and more attention has been paid to environmental factors by the energy industry and the public. With the concept and effect that consumers share pollution responsibility, its cost is increasingly accepted. In some countries, prices of many energy sources have increased in the last 20 years, partly taking into account environmental costs.

A frequently proposed solution for possible energy supply shortages is the increasing use of TES technologies, and the implementation of TES technologies can be very advantageous in many cases. To achieve benefits, engineers and designers should carefully consider the practicality, reliability, applicability and economy of TES. The low energy supply and public acceptability should be evaluated accordingly.

In a broader sense, it is pointed out that energy is one of the main factors to be considered in sustainable development discussions. Sustainable development, various definitions have been introduced including: "development that meets today's needs without compromising the ability of future generations to meet their own needs" [9]. Therefore, to ensure sustainable development, a completely sustainable supply of energy resources is required (that is, it can be used easily and sustainably at a reasonable cost in the long run and can be used for all necessary tasks without causing negative social impacts) ([10], [11], [12], [13]). Sustainable development

also requires a sustainable supply of energy and efficient use of energy resources, although a safe supply of energy resources is generally considered to be a necessary but not sufficient requirement for development in a community. In this context, the advantages of using TES are obvious.

### 4.3 Environmental problems

Over the past few decades, the risks and reality of environmental degradation have become increasingly evident. The environmental impact of human activities has increased significantly due to a combination of increasing world population, energy consumption, industrial activity and similar factors. During the 1970s, most of the environmental analysis and control devices concentrated on conventional pollutants such as SO<sub>2</sub>, nitrogen oxides (NO<sub>x</sub>), particles and CO. hazardous chemicals in small doses as well as globally important emissions such as CO<sub>2</sub>. Despite advances in environmental science, developments in industrial processes and structures have led to new environmental problems, such as an increase in the effects of NO<sub>x</sub> and volatile organic compound (VOC) emissions. Details of these gaseous and particulate pollutants and their effects on the environment and the human body can be found elsewhere [7].

Environmental problems span a continuously growing range of pollutants and hazards, and include ecosystem degradation over ever-wider areas. The major areas of environmental concern may be classified as follows [7]:

- acid rain,
- stratospheric ozone depletion,
- global warming and climate change,
- hazardous air pollutants,
- poor ambient air quality,
- water and maritime pollution,
- land use and siting impact,
- radiation and radioactivity,
- solid waste disposal, and
- major environmental accidents.

Among these environmental issues, the most internationally known and most significant ones are usually considered to be acid precipitation, stratospheric ozone depletion, and global climate change.

### 4.4 TES system and applications

TES systems can contribute significantly to meeting society's desire for more efficient, environmentally benign energy use, particularly in the areas of building heating and cooling and electric power generation. By reducing energy consumption, the utilization of TES systems results in two significant environmental benefits:

- the conservation of fossil fuels through efficiency increases and/or fuel substitution; and
- reductions in emissions of such pollutants as CO<sub>2</sub>, SO<sub>2</sub>, NO<sub>x</sub>, and CFCs.

TES can impact air emissions at building sites by reducing (i) the amount of ozone-depleting CFC and hydrochlorofluorocarbon (HCFC) refrigerants in chillers, and (ii) the amount of combustion emissions from fuel-fired heating and cooling equipment. Each of these impacts is considered. TES helps reduce CFC use in two main ways. First, since cooling systems with TES require less chiller capacity than conventional systems, they use fewer or smaller chillers with less refrigerant. Second, using TES can offset the lost cooling capacity that can sometimes occur when existing chillers are converted to more benign refrigerants, making building operators more willing to switch refrigerants.

The potential aggregate air-emission reductions at power plants due to TES have been shown to be significant. For example, TES systems have been shown to reduce CO<sub>2</sub> emissions in the United Kingdom by 14–46% by shifting electric load to off-peak periods [14], while an Electric Power Research Institute (EPRI) co-sponsored analysis found that TES could reduce CO<sub>2</sub> emissions by 7% compared to conventional electric cooling technologies [15]. Also, using California Energy Commission data indicating that existing gas plants produce

about 0.06 kg of NO<sub>x</sub> and 15kg of CO<sub>2</sub> per 293,100 kWh of fuel burned, and assuming that TES installations save an average of 6% of the total cooling electricity needs, TES could possibly eliminate annual emissions of about 560 t of NO<sub>x</sub> and 260,000 t of CO<sub>2</sub> statewide [16].

## **4.5 Solutions to environmental problems**

### **4.5.1 General solutions**

Various potential solutions to the current environmental problems associated with harmful pollutant emissions have recently evolved, including

- use of TES technologies;
- use of renewable energy technologies;
- energy conservation and increasing the efficiency of energy utilization;
- cogeneration and district heating and cooling;
- use of alternative energy forms and sources for transport;
- energy-source switching from fossil fuels to environmentally benign energy forms;
- use of coal-cleaning technologies;
- optimum monitoring and evaluation of energy indicators;
- policy integration;
- recycling;
- process change and sectoral modification;
- acceleration of forestation;
- application of carbon and/or fuel taxes;
- material substitution;
- promoting public transport;
- changing lifestyles;
- increasing public awareness of energy-related environmental problems;
- increased education and training.

### **4.5.2 TES-related solutions**

An important step towards the implementation of TES technologies is to identify and remove barriers. In the past, some obstacles have been identified in the development and launch of cleaner energy processes, devices and products. These barriers should be removed to make more use of TES and related technologies. Barriers can also affect the financing of efforts to increase the supply of TES technologies. Although there are some obstacles in practice, each TES project or application has its own challenges and obstacles.

Some of the barriers faced by many TES technologies include [4];

- technical constraints;
- financial constraints;
- limited information and knowledge of options;
- lack of necessary infrastructure for recycling, recovery, and re-use of materials and products;
- lack of facilities;
- lack of expertise within industry and research organizations, and/or lack of coordinated expertise;
- poorly coordinated and/or ambiguous national aims related to energy and the environment;
- uncertainties in government regulations and standards;
- lack of adequate organizational structures;
- lack of varied electrical rates to encourage off-peak electricity use;
- mismanagement of human resources;
- lack of societal acceptability of new TES technologies; and
- absence of, or limited consumer demand for, TES products and processes.

## 5. Energy savings

### 5.1 Introduction

Thermal energy storage (TES) is an important component of many successful thermal systems. TES should allow the highest favorable extraction efficiency of stored thermal energy, while allowing minimum reasonable thermal energy losses and associated energy savings. This section is about the methods of defining and evaluating TES systems and practical energy saving applications provided by using TES systems. The design and selection criteria of TES systems are examined. In addition, energy saving techniques and applications are discussed and highlighted with explanatory examples.

TES is considered by many to be an advanced energy technology, and there is growing interest in using this basic technology for thermal applications such as hot water, space heating, cooling, air conditioning, etc. TES systems have enormous potential to allow more efficient use of thermal energy equipment and to facilitate large-scale energy substitutions. The resulting benefits of such actions are particularly economically important. In general, a series of coordinated measures must be taken in various sectors of an energy system in order to realize the maximum potential benefits of TES. TES seems to be the best way to correct the mismatch that often occurs between thermal energy supply and demand. In a broader sense, TES can contribute significantly to meeting the more efficient, environmentally benign energy use needs of the community. Two main TES systems, which are sensitive (e.g. water and rock) and latent (e.g. water / ice and salt hydrates), offer economic and other advantages depending on the application. The choice of a TES system mainly depends on the required storage time, i.e. daily or seasonal and economic viability, working conditions, etc. It depends on other factors such as. In practice, many research and development activities continue to concentrate on efficient energy use and energy savings, leading to a wide range of energy saving measures. In this context, it seems that TES has an important role to play as it is an attractive thermal technology [13].

TES generally involves temporary storage of thermal energy at high or low temperature for later use. Examples of TES applications include storing solar energy during the night, summer heat for use in the winter, winter ice for cooling the area in the summer, and storage of heat or cooling produced by electricity during off-peak hours during the next peak. demand hours. Solar energy is not always available, unlike the energy of fossil fuels. Even cooling loads, which are almost the same as the maximum solar radiation level, are often found after sunset. TES provides an important mechanism to balance the mismatch between thermal energy availability and demand in this application. In other situations, where there is a discrepancy between energy production and use, TES can also assist in the efficient use and delivery of thermal energy. Various TES processes have been researched and developed for building heating and cooling, industrial energy efficiency improvement and utility power systems. Storage time is clearly an important factor. Daily storage systems have certain advantages: capital investment and energy losses are generally low, units are smaller and can be easily produced off-site, and daily storage sizing for each application is not as important as larger annual storage systems. . Annual storage systems are likely to be economical only in multi-dwelling or industrial park designs. Such systems often require expensive energy distribution networks and new institutional arrangements for ownership and financing. In Solar TES applications, when optimum energy storage time is integrated with the collection system and backup in the final application, it is usually the time that offers the final thermal energy at minimum cost [13].

The economic rationale for TES systems generally requires annualized capital and operating costs to be less than the annual costs of primary production equipment providing the same service loads and periods. TES is usually installed for two main reasons: (i) lowering initial costs and (ii) lowering operating costs. Usually, lower initial costs are possible when the thermal load is short-lived and has a long-time interval before the load returns, because in such cases a small storage is sufficient. Secondary capital costs may also be lower for systems with TES. For example, electrical service capacity can sometimes be reduced because energy demand is lower.

In order to conduct a comprehensive economic analysis of TES, initial costs must be determined. Equipment costs can be taken from the respective manufacturers and installation costs can be estimated. Cost savings and

net capital costs can be analyzed using the life cycle cost method or other applicable methods to determine which system is most suitable for a particular application.

Other issues to be considered in TES economic analysis are the space requirements and system reliability and the interface to the distribution system for implementation. The optimum energy storage application establishes a balance between maximizing the savings accrued in the grid fees and minimizing the initial cost of the installation required to achieve the savings. Consequently, the decision to install a storage system should be based on the predicted system loads, load characteristics, and capacity mix for a long time. Uncertainty about the future economic outlook, lifestyle changes and the availability of low-cost energy that charges the storage system can lead to different investment decisions if alternative technical solutions are possible. These uncertainties can change temporarily and spatially. In situations where TES systems are potentially attractive, the technical characteristics of alternative technologies may also influence decisions.

In this section, TES systems are examined from an energy saving perspective and possible energy saving technologies.

## 5.2 TES and energy savings

TES systems are an important element of many energy saving programs in the transportation industry as well as in residential, commercial, industrial and public services. TES can be used to reduce energy consumption or transfer an energy load from one period to another. Reducing consumption can be achieved by storing excessive thermal energy that will normally be released as waste, such as heat generated by equipment and devices, lighting, and even by passengers. Energy load transfer can be achieved by storing energy at a specific time for later use and can be applied to TES for heating or cooling capacity. Often, the main purpose of most TES systems, which will lead to financial savings by changing their energy saving habits, can be achieved in a variety of ways [5]: the energy consumption purchased, the storage of waste or the excess thermal energy available for use at certain times, other times. For example, solar energy can be stored throughout the day to warm up at night.

- Electricity demand purchased can be reduced by storing electricity generated by electricity during off-peak periods to meet the thermal loads that occur during high demand periods. There is growing interest in reducing peak demand or transferring energy loads from high consumption to low consumption periods. For example, an electric cooler can be used to charge a chilled water storage system at night to reduce electrical demand peaks, which often occur during the day.
- TES use can postpone the need to purchase additional equipment for heating, cooling or air-conditioning applications and reduce equipment sizes in new facilities. The related equipment is operated when the thermal loads are low to charge the TES, and the energy is drawn from the tank to help meet the thermal loads that exceed the equipment capacity. Each of these points is discussed separately in the three subsections below.

### 5.2.1 Utilization of waste or surplus energy

If a TES system is installed and charged using waste heat that is otherwise released into the environment, and energy is retained as an additional primary energy and then used, total energy consumption is reduced. In order to be economically viable, the cost of the replaced primary energy must exceed the activation, maintenance and operating costs of the TES system. The stored energy can be considered free in some sense, as it would otherwise be lost.

Useful waste or excess thermal energy can be obtained from many sources. (i) hot or cold water discharged into a sewage, (ii) hot flue gases, (iii) exhaust air streams, (iv) hot or cold gases or exhaust gases, (v) heat collected from solar panels, (vi) thermal from earth energy, (vii) the heat rejected from the condenser of the cooling and air conditioning equipment, and (viii) the cooling effect from the evaporator of a heat pump. Most TES applications in this category are designed for load balancing rather than waste energy recovery. The stored

thermal energy is higher than waste energy and is drawn from the conversion equipment during periods of low-end use demand for thermal energy. Such TES systems do not reduce energy use and can actually increase due to TES inefficiencies. For example, for a task delivered using a storage unit with a total energy efficiency of 75%, the total energy consumption will be one-third (ie  $1 / 0.75 - 1$ ) more than the energy consumption using the primary energy source directly. The purpose of such systems is not explicitly to reduce energy consumption, but to lower costs or allow scarce fuels to be replaced by more abundant fuels in an energy process.

Tomlinson and Kannberg [17] state that industrial production uses about a third of the total energy consumed in the USA, most of which are hydrocarbon fuels. Therefore, increasing energy efficiency in the industrial sector can have a significant impact on national energy consumption levels. TES is an important option to increase industrial energy efficiency. Flue gases use less thermal energy to be released to the environment and then use less purchased fuel, plant thermal emissions are reduced and product costs associated with fuel use are reduced. The following six industries, which make up about 80% of the total US industrial energy use, have the highest potential for energy savings with TES application: aluminum, brick and ceramic, cement, food processing, iron and steel and paper and pulp. Most of the existing TES systems in an industry are found in iron and steel plants where it is used as a regenerator to heat the air to about 600 airC. There are opportunities in other industries to recover waste heat from bulk gases. Estimates have shown that TES can potentially save up to 3 EJ per year in US industries.

Overall, TES can reduce the time or rate mismatch between energy supply and energy demand, thus playing a vital role in advanced energy management. Using TES can save premium fuel and reduce waste energy, making the system more cost-effective. TES can improve the performance of thermal systems by softening loads and increasing reliability. For this reason, TES systems are becoming increasingly important in many useful systems.

### 5.2.2 Reduction of demand charges

An important application of TES is to reduce electricity demand, thus reducing electricity demand charges. The reduction in demand charges is accomplished by eliminating or limiting electrical input to electrically operated heating or cooling devices during the peak electricity demand periods of a facility. The devices are operated before the peak occurs (eg, overnight) to charge TES systems. During the peak demand period, heating or cooling equipment does not work or operates at low levels, and thermal loads are met by the heating or cooling capacity of the storage.

The power supply that supplies power to the heating or cooling equipment can be turned off or power limiters installed to reduce electricity demand during peak periods. A number of devices can be energized and de-energized in accordance with TES operating strategies. Some examples are building heating, cooling and air conditioning, domestic water heating, process heating and cooling, cooling, snow melting, drying, ice making, etc.

The main purpose of cold storage is to provide a buffer between the cooler and the building cooling load, thus separating the cooling capacity and the work schedule from the building load profile, providing energy savings and demand savings and economic benefits through electricity consumption and electric load management. This TES application can be useful in various ways, regardless of the coolant energy source. In many practical applications, the aim is to maximize the use of facilities that produce efficient base load and eliminate the need for additional capacity. Benefits often justify offering rate incentives that favor load shifting and overcutting, and sometimes financial incentives to reduce storage costs.

Figure 2 gives an example of daily load profiles for a cold storage and cold storage building. Figure 2 (a) represents the safe without storage space, and Figure 2 (b) shows the full storage safe. In the second case, TES provides sufficient storage capacity to meet the peak (ie 09:00 - 21:00) cooling load by shifting all electricity demand for non-peak hours for cooling when there is a low cooling load. This particular application provides

maximum benefits in terms of reducing demand burden, both with lower operating costs, and the use of favorable off-peak rates.

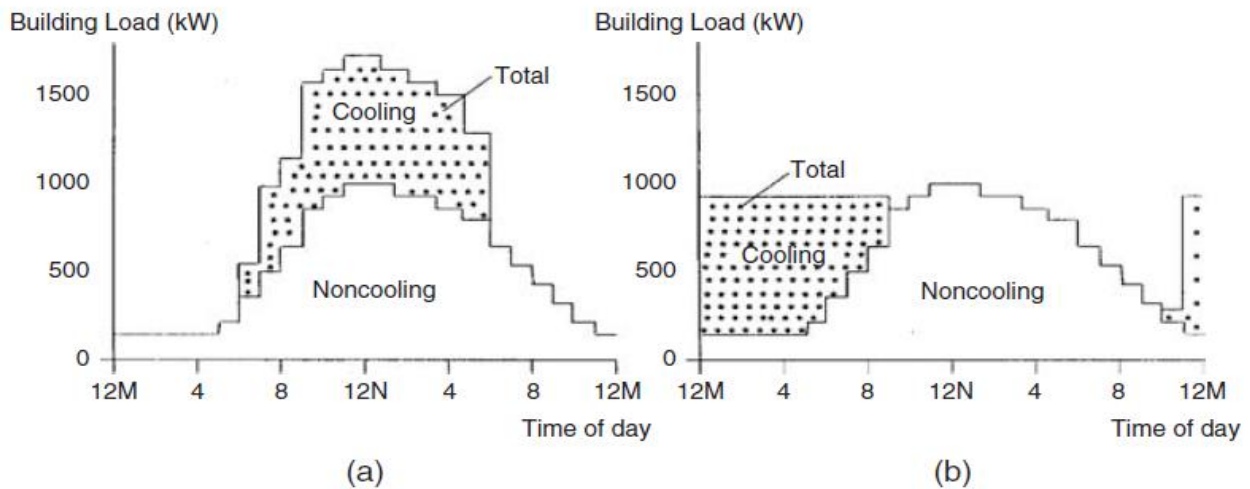

Figure 2. Daily load profiles of a building energy load: (a) no storage and (b) full storage [18]

### 5.2.3 Deferring equipment purchases

Heating and cooling equipment capacity is normally chosen to fit some of the design load when the heating and cooling requirements are close to the maximum. These peak design loads occur only for short periods of time and provide more capacity on average days. TES systems take advantage of the difference between peak and average thermal loads to provide the opportunity to postpone equipment purchases in a retrofit application or reduce equipment size in a new installation.

For example, consider a building with an average cooling load of 500 kW and a peak cooling load of 650 kW. The capacity of the current cooler is 750 kW. A proposed expansion will increase the average cooling load to 700kW and the peak to 850 kW. The new average load can be satisfied with existing equipment, but peak load cannot be satisfied. Depending on the traditional method, an additional 100kW cooler is required. As an alternative to supplying a new cooler, a TES system can be included to meet the highest cooling load. During off-peak hours, when the thermal load is less than the capacity of the current chiller, the chiller will work to maintain the desired building or process conditions and cool TES will be used to charge the chilled water TES system (or others to charge). When the cooling load exceeds the chiller capacity, chilled water is drawn from the tank. The benefits of the TES option may include capital savings and low operating costs. Reduced operating costs are due to the peak electric charge (and the corresponding demand load) being required to provide only 750kW of cooling instead of 850 kW and having less cooling equipment for maintenance. Note that in both cases, annual electricity consumption for cooling increases roughly in proportion to the new cooling loads [19]. The technique shown in the example above can also be used in new facilities. TES then allows the capacity of the thermal equipment to be selected close to the average rather than the peak condition.

## 6. Applications

### 6.1 Introduction

Over the past decade, a lot of research has been done on thermal energy storage (TES) in academia and industry, which is innovations in TES systems and applications, as well as TES types, materials, control strategies, measurement techniques and macro-nano-encapsulation processes. Advances in TES systems include new pumpable muds and microencapsulated phase change materials (MPCMs), which are interesting for applications ranging from building materials to new textiles that improve human comfort. New operating, control and

simulation strategies are developed for many TES applications. Many of the improvements may or may not be useful for designers.

Environmental issues, such as concerns about climate change and future use of fossil fuels, are increasingly being discussed by government agencies and the public. Given the community's interest in increasing the efficiency and cost-effectiveness of energy producing and consuming systems and reducing its environmental impact, new thermal systems have been introduced, including advanced cooling and heating methods. These are particularly important as the heating, ventilation and air conditioning (HVAC) systems in the residential, commercial and industrial sectors are responsible for most of the energy use in many countries. Thermal management research of energy systems often facilitates performance improvements.

The role of TES will increase, given the technology's ability to help manage HVAC systems costs and overall system efficiency during periods of intense and intense demand. For a cooling plant with a typical TES (Figure 3), peak energy demand and production times and durations generally do not overlap. Often the price of electricity and some other forms of energy varies throughout the day and season, often promoting efficiency and protection. Solar thermal systems generally require TES for periods ranging from daily to season. Cooling technologies often require sized cooling capacities for the highest electrical energy demands in the hottest daily periods. Suitable heat or cold storage improves these systems by storing the energy produced in non-peak periods for use in non-peak periods. This load compensation normally provides higher operating time at relatively lower and more stable capacities, reducing HVAC energy costs. The energy usage of an air conditioning system with and without a suitable cold TES can differ significantly [13].

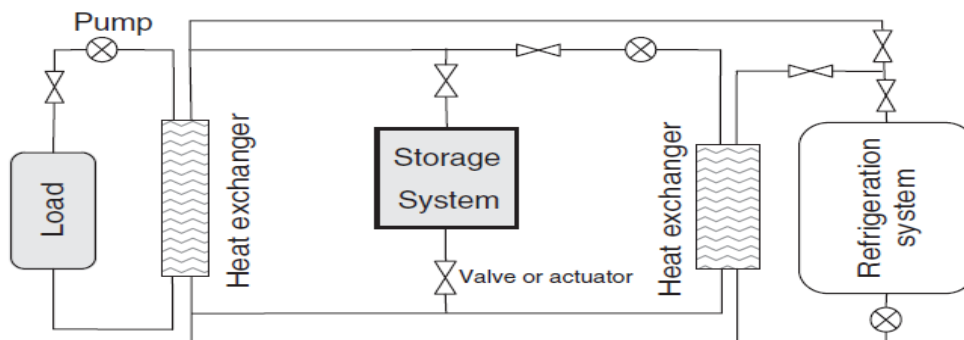

Figure 3. A cooling load serviced by a refrigeration system that incorporates thermal storage

## 6.2 Recent TES investigations

Many TES types and systems are available for cooling and heating and have been studied. TES performance depends on criteria such as type, size, storage medium and heat transfer fluid (HTF) materials, ambient temperature, constant or variable operating temperatures, and application.

Researchers and designers often look for the most effective TES performance parameters for a particular heating / cooling facility. The comfort level of the buildings can be improved by the proper integration of TES into a cooling or heating system.

It has been found that it is attractive to incorporate thermal storages in various shapes and cross sections filled with phased material (PCM) capsules in heating and / or cooling facilities [20]. In these tanks, an HTF below or above the solidification temperature of the PCM passes through TES. Capsules differ in shape and size and are made from materials such as plastic (eg, Polyethylene) and metal, depending on usage, demand and charge / discharge rates. Most PCM do not have a constant phase change temperature, so temperature-related enthalpy correlations obtained by calorimetric methods based on nucleation temperatures are often used [21].

Cold thermal energy storage (CTES) can be actively or passively integrated into an HVAC system. Active methods result in lower operating costs, but are complex, including components such as pumps, pipeline distribution lines, heat exchangers and valves / actuators. Passive methods integrate PCMs with appropriate



melting temperatures into building materials such as walls and ceilings, or inside the duct in suitable locations (eg window openings). In some cases, they are used in passive systems to increase heat transfer rates. Passive systems store cold from night air for daytime cooling and vice versa. Similarly, passive TES can be used with solar energy, which also facilitates efficient energy management [22]. Active and passive cooling / heating can be used together to reduce HVAC energy requirements and operating costs and increase comfort in indoor and working areas.

Economic factors play an important role in production methods and applications for new TES developments and technological innovations. Thermal management based on fluid flow, heat transfer and thermodynamic (including exergy) analysis is also important. These disciplines together enable the most appropriate TES designs within the constraints, boundary and environmental conditions (Figure 4).

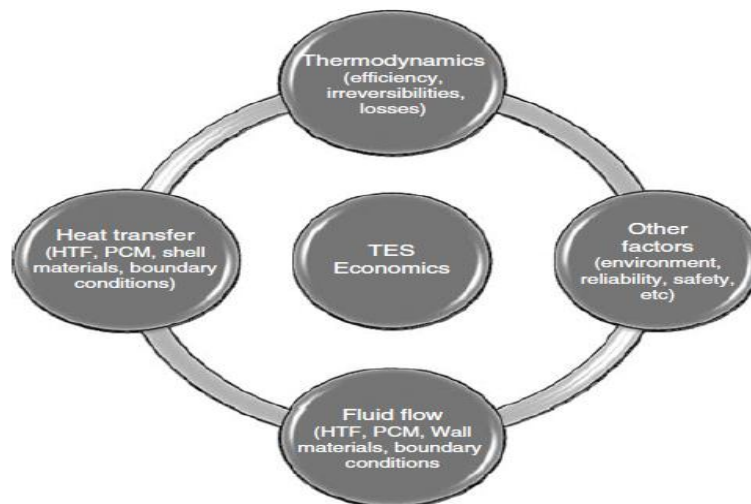

Figure 4. Illustration of the effect on the economics of TES systems and applications of thermofluids and other considerations

### 6.3 Developments in TES types and performance

Some basic aspects of PCMs and HTFs in TES systems are discussed in this section. Important factors affecting the storage performance and the operation and efficiency of the heating / cooling system are shown in Figure 5.

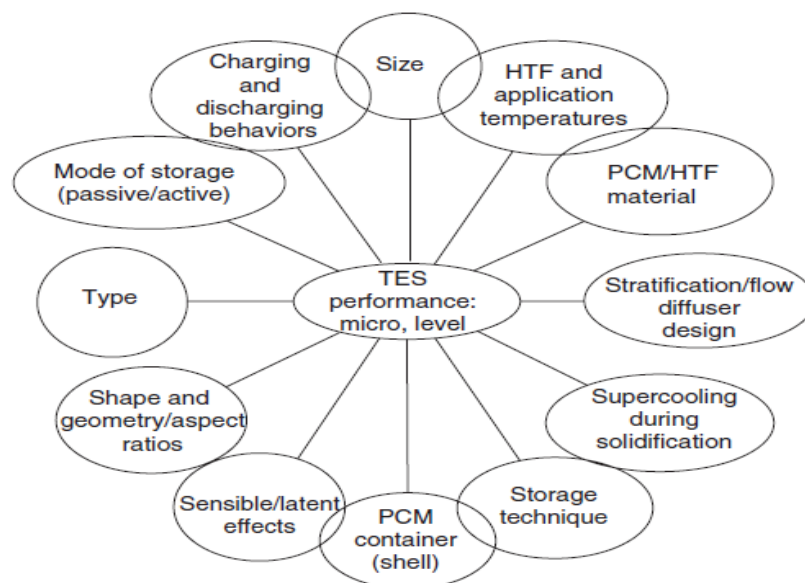

Figure 5. Parameters that affect TES performance at the micro level [13]

➤ Nano- to Macro-Size Storage Media or PCM Particles and Capsules

Thermal storage media sizes generally vary from some cubic centimeters to some cubic meters, depending on the application for heating or cooling. Many studies have been reported in TES systems based on the size of the storage medium, PCM or storage container. Mawire et al. [23] examined the gravel glass bed as a fast-sensitive thermal storage for cooking and heating in solar concentric systems.

Data from experiments on these PCM dimensions were compared to packed bed / gas (e.g. Air) simulations. Average temperatures of oil and gravel (100–300 °C) were found for different charging rates. Charge flow rate depends on the volumetric heat transfer coefficient and experimentally, a relation was found between HTF average speed, average gravel diameter and volumetric heat transfer rate. Since water is not a good choice for storage temperatures above 100 °C (unless expensive pressurization is added), oils are used for heating in solar collector systems. Mawire and MacPhee [24] experimentally validated a sandy gravel / oil TES system for a variable heat source and determined the axial temperature distribution for the system. Sandy pebbles can also be used as a sensitive storage medium for cooking with an oil HTF.

Rady [25] examined the performance of granular bed pebbles in the 1-3 mm diameter range. DSC and temperature history (T-date) methods have been used to determine the phase transition properties (melting point, latent heat and total heat energy capacity) considering the granular (gravel) PCM particles. In another study, Mawire et al. [26] investigated three gravel materials (silica, glass and alumina) and determined the ratio of total exergy to total energy stored and thermal stratification performance. Silica showed better thermal stratification, and alumina showed the highest total exergy / energy ratio variations stored during the duration of the experiment and was initially loaded fastest.

PCM size has a significant effect on heat transfer rates between PCMs and HTFs and affects HTF pressure drop. The PCM particle (or capsule) size also affects the total heat capacity of a fluid in which small PCM particles are dispersed as a secondary coolant. Since these factors affect the performance of a plant integrated into a TES system, the impact of the PCM size is obvious. Microcapsules may be allowed to be part of HTF for some PCMs (eg Pumpable encapsulated PCM slurries). In such cases, the size of PCM particles or capsules varies from some nanometers to a few millimeters. Various factors should be considered in the development of a new microencapsulated PCM [27]:

- particle size profile (spectrum);
- mean particle size;
- surface characteristics and morphology of the particles (or capsules);
- phase-transition temperature (range);
- chemical nature (shell and PCM core material specifications);
- stability;
- thermal and mechanical cycling reliability and durability (e.g., during melting/freezing or continuous pumping);
- volumetric change during thermal cycles.

The heat transfer interface between an HTF and PCM can be enhanced by reducing the size of the PCM particles (or capsules) and mixing them homogeneously into HTF, thereby forming a phase shift slurry as a secondary coolant (Figure 6). Such slurries can be produced by a coacervation process in which micro-dimensional droplets of an organic substance such as oil or paraffin wax (1 μm to 1 mm diameter depending on the agitation / mixing process) are held by hydrophobic forces. MPCM slurries have different applications from functional thermoregulated fibers (used in textile industries), solar energy and heat transfer development to various material uses in the agriculture, biology and construction industries [28]. DSC and other measurement procedures have recently been proposed to evaluate MPCM thermal properties and durability.

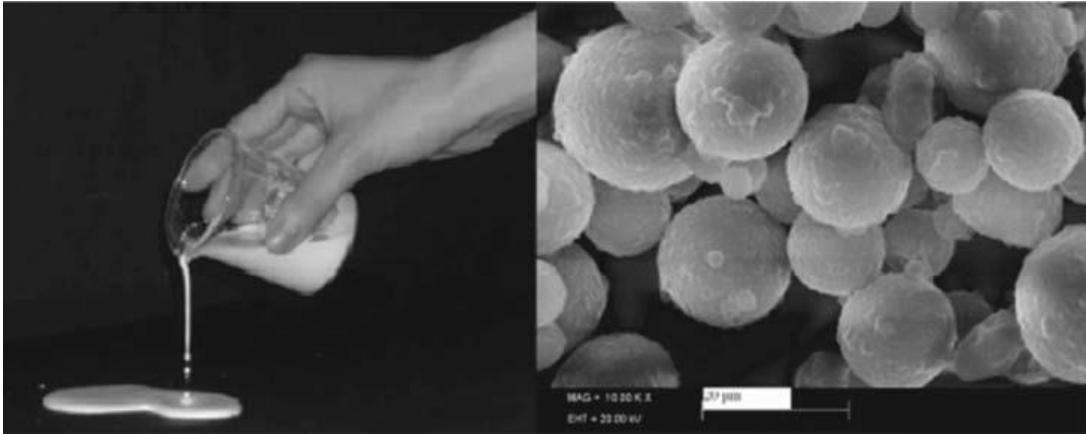

Figure 6. Flowing microencapsulated PCM as a phase-change slurry [29]

The procedures required before introducing a new MPCM into an industrial application have been described [30].

The many physical and chemical steps and procedures to produce MCPMs can be categorized on the basis of the following production methods:

- coacervation (chemical) [27] and solvent evaporation–precipitation (physical) [31],
- blending and comparison molding [32],
- interfacial polycondensation [33],
- phase separation [34].

#### 6.4 Future perspectives

Many new applications of TES systems are expected to evolve to improve thermal management for thermal systems, including improved waste heat / cold recovery, electrical circuit cooling, energy management in electric and fuel cell vehicles, and photovoltaic battery cooling.

Energy concerns will continue to be significant concerns for the reduction of energy systems and performance optimization of engineering systems, TES systems and their use in industry. Thermodynamics, especially second law issues, will become increasingly important in evaluating and improving efficiency, and exergy breakdown will be an important benchmark for meaningful measurement of entropy produced in a TES-based system and its components. Research to improve the performance and efficiency of thermal systems containing TES and to develop improved materials, storage configurations and operational strategies, especially when relevant to industry, will almost certainly continue.

Using TES systems as thermal capacitors in cooling or HVAC facilities will probably facilitate more energy use. To better design TES systems, it is necessary to better understand the behavior of parameters such as speed, temperature and pressure. In thermodynamic analysis, optimization and design, numerical approaches can be expected to be quantified for these and other parameters such as temperature. The explanation of the dynamic behavior of thermal systems, including TES, obtained through simulation and experimentation, will become increasingly necessary to develop advanced operational strategies and practices.

It is important to choose a TES type suitable for application and environmental conditions. Comprehensive design methodologies based on relevant criteria such as thermodynamics, economy, environmental impact and other factors will be increasingly needed.

Although most of the material covered in this section focuses on TES components and micro-level issues for charge and discharge under constant conditions, wider macro-level issues will be needed such as thermoeconomic analysis of TES systems and their inclusion in HVAC. This information can help improve operating strategies and setup configurations, and facilitate optimization. Efforts to reduce internal and external exergy losses due to irreversibilities during TES charging, storage and discharge are likely to increase. Extensive

work on related parameters and systems will become increasingly important to assist future design efforts. Advanced technology transfers between researchers and designers involved in TES will continue to be important to ensure that researchers understand the industry's needs and are aware of the industry's new TES developments.

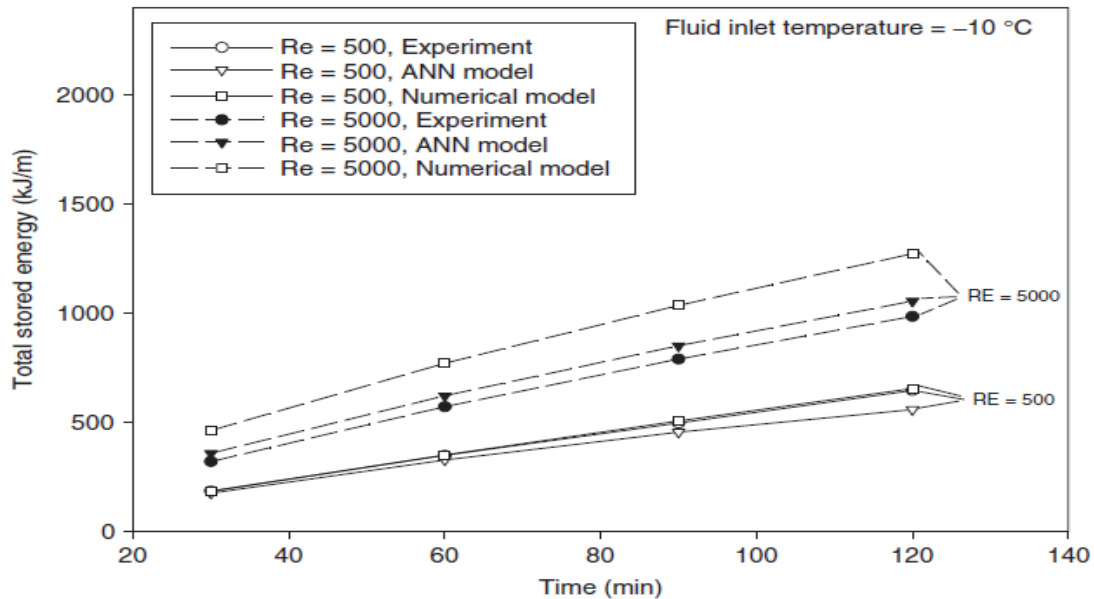

Figure 7. Variation of total stored thermal energy with time, using the ANN approach, the numerical model, and experimental data, for Re = 500 and 5000 and a HTF inlet temperature of  $-10\text{ }^{\circ}\text{C}$  [35]

Also, the ANN and numerical approaches are compared with experimental data for the total stored thermal energy at Re = 500 and 5000, for an inlet HTF temperature of  $-10\text{ }^{\circ}\text{C}$  in Figure 7. Although these figures demonstrate that both ANN and numerical results are close to the experimental data at Re = 500, the ANN approach provides better agreement than the numerical model at Re = 5000 for both HTF inlet temperatures.

A validation of the ANN model, which is an important step in ensuring the reliability of results, is reported by Ermis et al. [35]. Overall, the ANN approach appears to be a promising tool for thermal analysis of both latent and sensible TES systems.

## 7. Conclusions

The following conclusions can be drawn from this study:

- The different ES systems have their own advantages and disadvantages and are suitable for different forms of energy. In cases where thermal energy is present and thermal demands are present but not necessarily random, TES is the most direct tool of ES, as it prevents the need to convert energy from one form to another and subsequent loss of transformation. Especially when it comes to solar energy, TES seems to be the most efficient and effective storage medium. Therefore, TES is likely to have solar thermal applications in the future.
- Although energy can be stored in many ways (for example, in mechanical, kinetic or chemical forms), the storage of thermal energy requires attention, as most of the economy includes thermal energy. TES deals with the storage of energy by cooling, heating, melting, solidifying or evaporating a material; When the process is reversed, the energy becomes available as heat. TES is the temporary storage of high or low temperature energy for later use. There are basically two types of TES systems: sensitive (eg, Water and rock) and latent (eg Ice and salt hydrates). Storage of a material by causing it to increase or decrease is called logical heat storage. Its effectiveness depends on the specific heat of the material and the density of the storage material, if volume is important. Storage with phase change, transition from solid to liquid or liquid to vapor without change in temperature is known as latent heat storage.

TES can help address the mismatch between energy supply and demand and can significantly contribute to meeting the society's more efficient, environmentally benign energy use needs. Therefore, TES plays an important role in energy saving and can significantly save on premium fuels.

c. There are a number of environmental issues we face today. These problems include constantly increasing pollutants, hazards and ecosystem degradation in the ever-expanding areas. The most important problems are acid deposition, stratospheric ozone depletion and global climate change. The second is potentially the most important environmental problem with energy use. Increasing atmospheric greenhouse gas concentrations increase the way these gases capture heat from the surface of the soil, thereby raising the surface temperature of the earth and consequently sea levels.

Recently, several potential solutions have developed for existing environmental problems related to harmful pollutant emissions. TES seems to be an effective solution and plays an important role in environmental policies.

d. The main advantages of using TES can be summarized as follows:

- While applying techniques such as using waste energy and residual heat, reducing electricity demand fees and preventing heating, cooling or air conditioning equipment purchases, significant energy savings can be achieved by using TES. This energy saving can be achieved even though the ratio of storage energy efficiency to the input amount of thermal energy drawn from the storage is less than 100%. Storage energy losses are generally small, for example up to 90% energy efficiency can be achieved in well layered water tanks that are fully charged and discharged in the daily cycle.
- TES plays an important role in meeting the more efficient use needs of the society in various sectors, as it allows for the mismatch between supply and energy demand to be eliminated.
- With TES, peak period demand for electrical energy can be reduced in order to store the thermal energy produced by electricity during off-peak periods and to meet the thermal loads that occur during high demand periods. For example, a cooler can charge TES at night to reduce the highest electricity demands during the day.
- TES offers tremendous potential for more efficient use of TES equipment and to facilitate economically large-scale energy substitutions. The economic justification for TES systems requires that the annual income normally required to cover capital and operating costs is less than that required for primary production equipment supplying the same service loads and periods. A series of coordinated actions are required in various energy sectors to achieve maximum benefit from storage.

## References

- [1] R. A. Huggins, *Fundamentals, Materials and Applications*, Springer, Switzerland, 2016.
- [2] I. Dincer, I. and M. A. Rosen, *Energy: Energy, Environment and Sustainable Development*, Elsevier, New York, 2007.
- [3] I. Dincer, *Heat Transfer in Food Cooling Applications*, Taylor & Francis, Washington, DC, 1997.
- [4] I. Dincer, "Evaluation and selection of energy storage systems for solar thermal applications", *International Journal of Energy Research*, vol. 23, pp. 1017–1028, 1999.
- [5] I. Dincer, S. Dost, and X. Li, "Performance analyses of sensible heat storage systems for thermal applications", *International Journal of Energy Research*, vol. 21, no. 10, pp. 1157–1171, 1997.
- [6] M. A. Rosen, I. Dincer, and N. Pedinelli, "Thermodynamic performance of ice thermal energy storage systems", *ASME-Journal of Energy Resources Technology*, vol. 122, no. 4, pp. 205–211, 2000.
- [7] I. Dincer, "Energy and environmental impacts: present and future perspectives", *Energy Sources*, vol. 20, no. 4/5, pp. 427–453, 1998.
- [8] I. Dincer, "Renewable energy and sustainable development: a crucial review", *Renewable and*

*Sustainable Energy Reviews*, vol. 4, no. 2, pp. 157–175, 2000.

- [9] Anon., *Our Common Future*, World Commission on Environment and Development, Oxford University Press, Oxford, 1987.
- [10] R. Norton, *An Overview of a Sustainable City Strategy*, Report Prepared for the Global Energy Assessment Planning for Cities and Municipalities, Montreal, Quebec, 1991.
- [11] K. M. MacRae, *Realizing the Benefits of Community Integrated Energy Systems*, Canadian Energy Research Institute, Alberta., 1992.
- [12] M. A. Rosen, “The role of energy efficiency in sustainable development”, *Technology and Society*, vol. 15, no. 4, pp. 21–26, 1996.
- [13] I. Dincer, and M. A. Rosen, “A worldwide perspective on energy, environment and sustainable development”, *International Journal of Energy Research*, vol. 22, no. 15, pp. 1305–1321, 1998.
- [14] C. B. Beggs, “Ice thermal storage: impact on United Kingdom carbon dioxide emissions”, *Building Services Engineering Research and Technology*, vol. 15, no. 1, pp. 756–763, 1994.
- [15] D. T. Reindl, *Characterizing the Marginal Basis Source Energy Emissions Associated with Comfort Cooling Systems*, Thermal Storage Applications Research Center, Report No. TSARC 94-1, USA, 1994.
- [16] CEC., *Source Energy and Environmental Impacts of Thermal Energy Storage*, California Energy Commission, Technical Report No. P500-95-005, California, 1996.
- [17] J. J. Tomlinson, and L. D. Kannberg, “Thermal energy storage”, *Mechanical Engineering*, vol. 112, pp. 68–72, 1990.
- [18] I. Dincer, S. Dost, and X. Li, “Thermal energy storage applications from an energy saving perspective”, *International Journal of Global Energy*, vol. 9, pp. 351–364, 1997.
- [19] Anon., *Thermal Storage*, Energy Management Series No. 19, Energy, Mines and Resources, Canada, 1985.
- [20] M. Cheralathan, R. Velraj, and S. Renganarayanan, “Effect of porosity and the inlet heat transfer fluid temperature variation on the performance of cool thermal energy storage system”, *Heat Mass Transfer*, vol. 43, pp. 833–842, 2007.
- [21] E. Gunther, H. Mehling, and S. Hiebler, “Modeling of subcooling and solidification of phase change materials”, *Modelling and Simulation in Materials Science and Engineering*, vol. 15, pp. 879–892, 2007.
- [22] C. Arkar, and S. Medved, “Influence of accuracy of thermal property data of a phase change material on the result of a numerical model of a packed bed latent heat storage with spheres”, *Thermochimica Acta*, vol. 438, pp. 192–201, 2005.
- [23] A. Mawire, M. McPherson, R. R. J. van den Heetkamp, and S. H. Taole, “Experimental volumetric heat transfer characteristics between oil and glass pebbles in a small glass tube storage”, *Energy*, vol. 35, pp. 1256–1263, 2010.
- [24] D. MacPhee, and I. Dincer, “Thermal modeling of a packed bed thermal energy storage system”, *Applied Thermal Engineering*, vol. 29, pp. 695–705, 2009.
- [25] M. Rady, “Granular phase change materials for thermal energy storage: experiments and numerical simulations”, *Applied Thermal Engineering*, vol. 29, pp. 3149–3159, 2009.
- [26] A. Mawire, M. McPherson, R. R. J. van den Heetkamp, and S. J. P. Mlatho, “Simulated performance of storage materials for pebble bed thermal energy storage (TES) systems”, *Applied Energy*, vol. 86, pp. 1246–1252, 2009.
- [27] Y. Ozonur, M. Mazman, H. O. Paksoy, and H. Evliya, “Microencapsulation of coco fatty acid mixture for thermal energy storage with phase change material”, *International Journal of Energy Research*, vol. 30, pp. 741–749, 2006.
- [28] J. Su, L. Ren, and L. Wang, “Preparation and mechanical properties of thermal energy storage microcapsules”, *Colloid and Polymer Science*, vol. 284, pp. 224–228, 2005.
- [29] X. Wang, J. Niu, and A. H. C. van Paassen, “Raising evaporative cooling potentials using combined cooled ceiling and MPCM slurry storage”, *Energy and Buildings*, vol. 40, pp. 1691–1698, 2008.

- [30] J. L. Alvarado, C. Marsh, C. Sohn, G. Phetteplace and T. Newell, “Thermal performance of microencapsulated phase change material slurry in turbulent flow under constant heat flux”, *International Journal of Heat and Mass Transfer*, vol. 50, pp. 1938–1952, 2007.
- [31] F. Salaun, E. Devaux, S. Bourbigot, and P. Rumeau, “Influence of the solvent on the microencapsulation of a hydrated salt”, *Carbohydrate Polymers*, vol. 79, pp. 964–974, 2010.
- [32] J. Li, P. Xue, W. Ding, J. Han, and G. Sun, “Micro-encapsulated paraffin/high-density polyethylene/wood flour composite as form-stable phase change material for thermal energy storage”, *Solar Energy Materials and Solar Cells*, vol. 93, pp. 1761–1767, 2009.
- [33] H. Zhang and X. Wang, “Synthesis and properties of microencapsulated n-octadecane with polyuria shells containing different soft segments for heat energy storage and thermal regulation”, *Solar Energy Materials and Solar Cells*, vol. 93, pp. 1366–1376, 2009.
- [34] R. Yang, Y. Zhang, X. Wang, Y. Zhang, and Q. Zhang, “Preparation of n-tetradecane-containing microcapsules with different shell materials by phase separation method”, *Solar Energy Materials and Solar Cells*, vol. 93, pp. 1817–1822, 2009.
- [35] K. Ermis, A. Ereğ and I. Dincer, “Heat transfer analysis of phase change process in a finned-tube thermal energy storage system using artificial neural network”, *International Journal of Heat and Mass Transfer*, vol. 50, pp. 3163–3175, 2007.